

DV-95252

Dual Head DVI/VGA USB KVM Extender over IP

The DV-95252 is a perfect solution for Dual head DVI/VGA + Audio USB KVM Extender over Gigabit IP Ethernet. The system includes DV-95252T Dual head Transmitter and DV-95252R Dual head Receiver. The Transmitter connects to PC's 2 DVI/VGA, Audio, and USB; the Receiver connects to 2 DVI/VGA displays, speaker, microphone, and USB devices.



The solution is based on standard of IP technology. The Transmitter converts input signals (video, audio, USB) and directly sends to the Receiver. On the other end of Receiver, receiving directly from the Transmitter then converts back to video, audio, USB... and sends to display, speaker, USB devices. It is a perfect solution for the Central Control Room Dual Head DVI/VGA KVM applications.

Features

- ❖ Support Dual head DVI/VGA video 1080p or PC 1920 x 1200 @ 60Hz resolution.
- ❖ Based on Gigabit Ethernet, easy cabling, easy installation, easily maintain.
- ❖ The DVI-I connector supports HDMI/DVI/VGA.
- ❖ Support generic USB 2.0 extension, can be used for keyboard, mouse, touch screen, storage.
- ❖ Support both HDMI and 3.5mm stereo audio.
- ❖ The Receiver supports 3.5mm microphone.
- ❖ Pure hardware design, plug-and-play, no any additional software is required.
- ❖ Support Web GUI for the unit configuration.
- ❖ FCC, CE, RoHS.

Front and Rear View

DV-95252T (Transmitter)

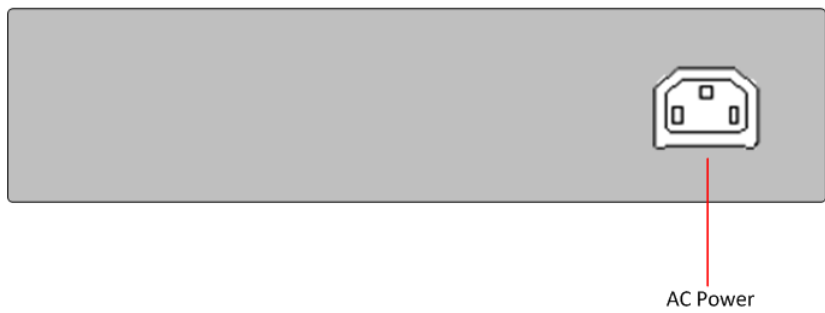
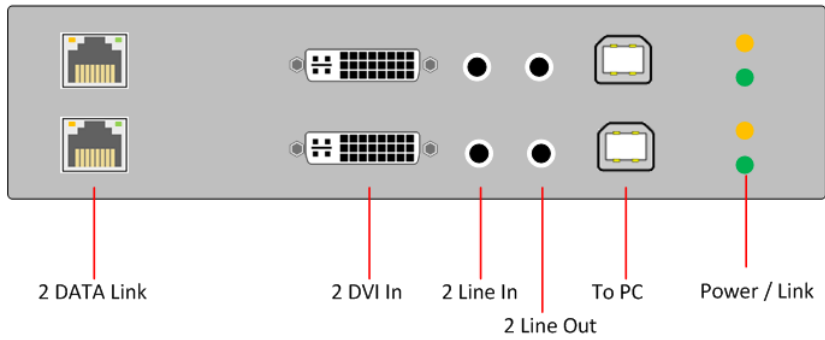

DV-95252R (Receiver)

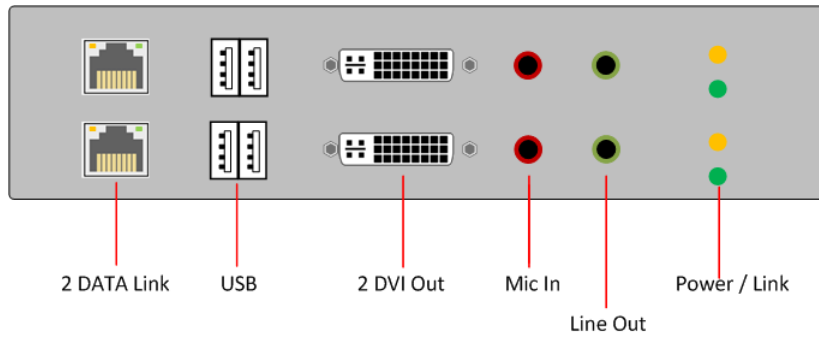

Specification

Model No.		DV-95252T Transmitter	DV-95252R Receiver
Connectors	HDMI/DVI-I Input	2	N/A
	HDMI/DVI-I Output	N/A	2
	USB	2 x USB-B to PC	4 x USB-A
	Audio	2 x Line-In, 2 x Line-Out	2 x MIC-In, 2x Line-Out
	Power	AC 100 ~ 240V	
	System Port	2 x RJ45 Gigabit	
Resolution		1080p or PC 1920 x 1200 @ 60Hz	
Inter-connect Cable		CAT 6 / 7	
Environment	Operation Temperature	0~50°C	
	Storage Temperature	-20~ 85°C	
	Humidity	0~80% Non-condensing	
Physical Properties	Material	Metal (Black)	
	Weight	1100 g	1100 g
	Dimension	170x150x50 mm	170x150x50 mm

Diagram

